

SETTING UP THE 4572F3

Make sure to place your fountain on a firm area which will not settle. Note: Always follow local electrical codes and use a 110V GFCI protected outlet. Do not let children climb on fountain.

1) Place the Fountain Pedestal on its prepared site. Turn the access hole at the bottom toward your electrical connection.

2) Set the 4572B Basin on the pedestal. Place pump in basin and run its power cord down through the center hole. Two people are needed now. One person should gently lean the basin and pedestal over while the other pulls the pump cord out from under the pedestal, aligning it with the cast access hole at the bottom edge. Then thread the smaller adapter into the pump top.

3) Lay the 4572A Fountain Top on its side nearby. Slip the Diffuser Tube into the hole in the top, internal ring up. Then insert the light cord into the diffuser tube and pull the light cord out the other end until the Light nests on the internal ring within the diffuser tube. Hold the Slotted Adapter near the bottom of the 4572A top and place the light cord in the adapter's slot (in the threaded end). Then gently thread the adapter into the coupling underneath the 4572A top. Push the Water Tube onto the barb of the slotted adapter.

(Do not connect the tube directly to the Plume Light.)

4) Insert the loose end of the light's power cord into the hole in the 4572B basin, doing the same thing you did with the pump cord until you have both power cords pulled out of the bottom access hole. Back in the basin, seal up the basin hole with the rubber stopper. Open its slits and place both cords within the correctly sized grooves provided. Close the slits and press the small end of the stopper into the hole until just 1/8" remains above the basin floor.

5) One person should lift and hold the 4572A top over the 4572B Basin while the other pushes the open end of the water tube onto the pump's barbed adapter. Then set the top down around the pump and cords, centering it in the basin.

6) Fill all bowls and pool with water. Read pump and light instructions. Turn on the power. If the pump does not immediately begin working, there may be an "airlock" within the impeller chamber. Simply unplug and plug in a few times and it should start. Csd 7/2021

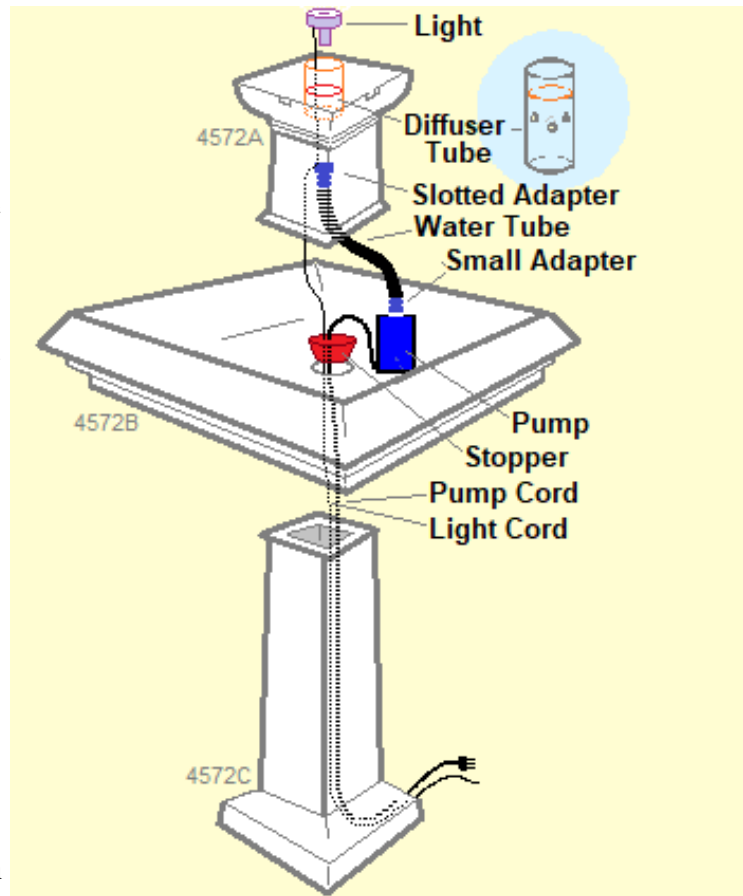

Online Resources
Products: www.henristudio.com/products
FAQs: www.henristudio.com/faq
Warranty: www.henristudio.com/warranty
Contact : www.henristudio.com/contact-us

Caution: The use of Chlorine or Chlorine Bleach or water coloring additives may damage the finish of your fountain.

IMPORTANT – WINTER CARE

Winter ice build-up can cause damage to concrete statuary. Follow these tips to reduce winter weathering to your fountain:

- * Disconnect power to pumps and lights.
- * Remove plugs/stoppers in all fountain bowls to open drains and let all moisture out. Keep drains open throughout winter.
- * Cover with a Henri fountain cover. Keep tight and do not let snow or water collect in sagging areas.
- * Do not allow snow or ice to build up on or against the concrete. Remove snow before it turns to ice. Do not use antifreeze, salt or chemical ice removers as these may damage concrete.