

SETTING UP THE 5018F

1) Set the 6018 Basin in the center of your prepared site. Make sure basin is level. The cord exit slot on the rim of the basin will indicate the back of the fountain over which the power cords will exit.

2) Place the 5018B Fenelon Column on its side on protective material (burlap, excelsior, towel, etc.). Connect the two longer water tubes to the barbed fitting at the bottom of the lights.

3) Slip the light with the longer tube and its power cord down through the hole at the top of the column, tube and cord first. Slip the other light into the hole in the lower front of the column, also tube and cord first.

4) Hold the Large Barbed Adapter in one hand and slip the light power cord from the light on top into the slot cut into the threads of the adapter. This should be done at the bottom of the column where the light cord exits the statue. Once the cord is in the slot, gently thread the adapter into place under the column.

5) Place the Pump in the basin and run its power cord out the back of the basin. Thread the Small Barbed Adapter into the top of the pump. Attach remaining tube to barb.

6) Install the Flow Restrictor on the tube under the lower light, as pictured. Then push this tube onto the middle leg of the tee. Push the tube from the upper light onto a straight leg of the tee.

7) With assistance, set the column onto the basin – draping the light cords out the basin’s back and connecting the short tube from the pump to the remaining leg of the tee as you lower the column into place.

8) Set the 5018A Cap on the column. Fill basin with water. Read pump and light instructions. Turn on the pump. If it does not immediately begin working, there may be an “airlock” within the impeller chamber. Simply unplug and plug in a few times and it should start. Tighten the flow restrictor to adjust the water balance as you prefer.

Make sure to place your fountain on a firm and level surface which will not settle. Note: Always follow local electrical codes and use a 110V GFCI protected outlet. Do not let children climb on fountain.

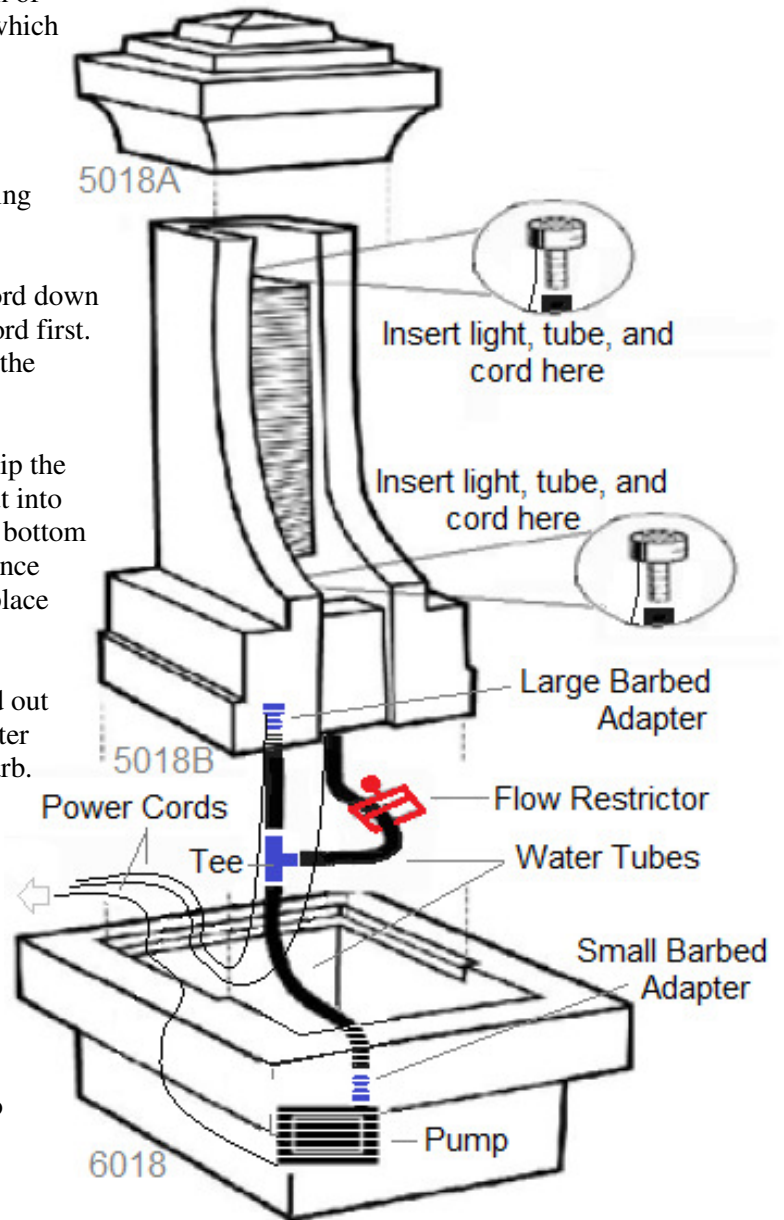

Csd

6/2022

Online Resources

Products: www.henristudio.com/products
FAQs: www.henristudio.com/faq
Warranty: www.henristudio.com/warranty
Contact : www.henristudio.com/contact-us

Caution: The use of Chlorine or Chlorine Bleach or water coloring additives may damage the finish of your fountain.

IMPORTANT – WINTER CARE

Winter ice build-up can cause damage to concrete statuary. Follow these tips to reduce winter weathering to your fountain:

- * Disconnect power to pumps and lights.
- * Remove plugs/stoppers in all fountain bowls to open drains and let all moisture out. Keep drains open throughout winter.
- * Cover with a Henri fountain cover. Keep tight and do not let snow or water collect in sagging areas.
- * Do not allow snow or ice to build up on or against the concrete. Remove snow before it turns to ice. Do not use antifreeze, salt or chemical ice removers as these may damage concrete.