

SETTING UP THE 5621F & 5625F

Make sure to place your fountain on a firm area which will not settle. Note: Always follow local electrical codes and use a 110V GFCI protected outlet.

1) Place 6624 fountain bowl on your prepared setting with the notch for the cord turned toward your electrical power source.

2) Place pump in the middle of the bowl. Slip the pump power cord down through the hole near the center of the bowl and pull it out toward your power source.

3) Open the slit in the stopper and install it around the pump cord just above the hole in the bowl. Then press the stopper firmly into the hole to create a watertight bowl.

4) Thread the smaller adapter into the pump.

5) Thread the larger adapter up inside the bottom of the 5621 or 5625 fountain top. Push one end of the water tube over the barb end of this larger adapter.

6) As you lower the 5621 or 5625 fountain top into the bowl, push the other end of the water tube onto the barb of the pump adapter. Set the fountain top on the bowl, safely around the pump. Check to make sure it is level. (Shims are included to help adjust the level once the water is running.)

7) Read your pump instructions. Fill the bowl with water. Plug in the pump. If the pump does not immediately push water it may have an air-lock in the impeller chamber. You can clear this easily by simply unplugging and re-plugging the pump a few times.

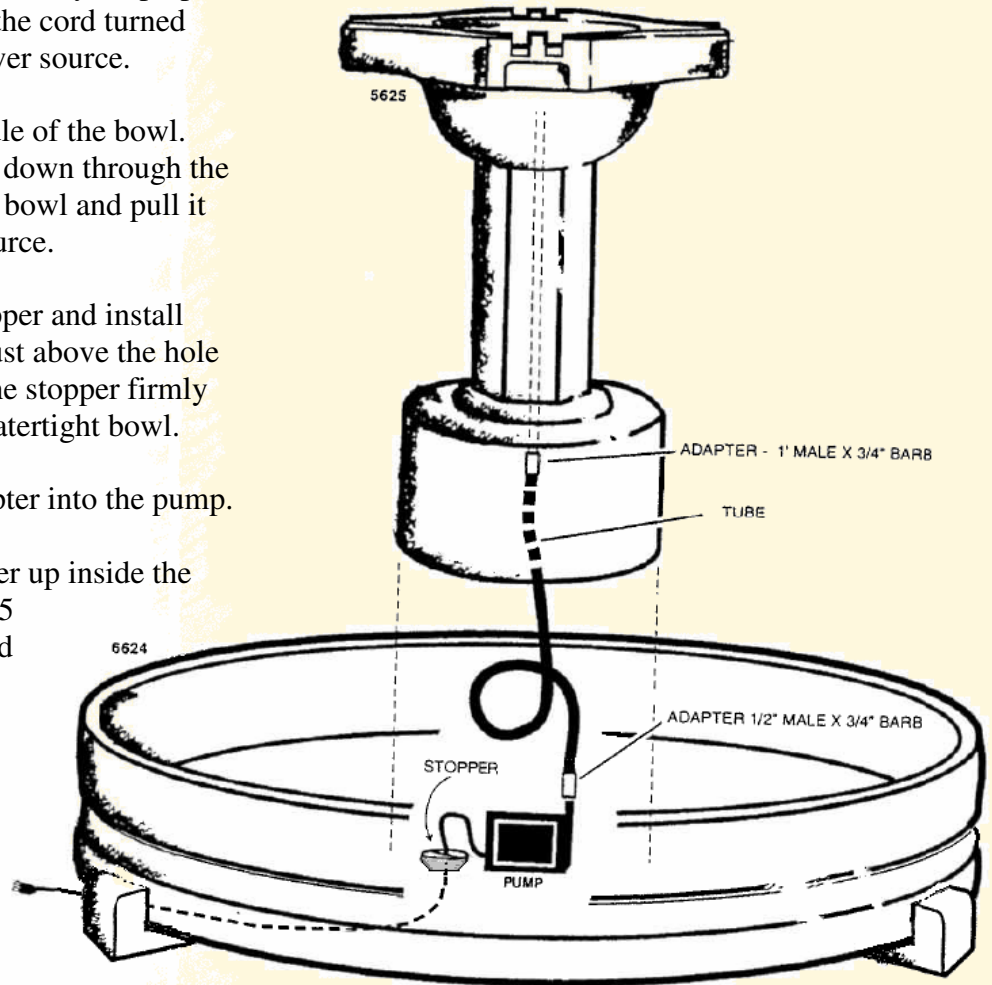

4/19

Online Resources

Products: www.henristudio.com/products
FAQs: www.henristudio.com/faq
Warranty: www.henristudio.com/warranty
Contact: www.henristudio.com/contact-us

Caution: The use of Chlorine or Chlorine Bleach or water coloring additives may damage the finish of your fountain.

IMPORTANT – WINTER CARE

Winter ice build-up can cause damage to concrete statuary. Follow these tips to reduce winter weathering to your fountain:

- * Disconnect power to pumps and lights.
- * Remove plugs/stoppers in all fountain bowls to open drains and let all moisture out. Keep drains open throughout winter.
- * Place an absorbant material like burlap, blankets, etc. inside vases/bowls and cover all with a Henri fountain cover.
- * Do not allow snow or ice to build up on or against the concrete. Remove snow before it turns to ice. Do not use antifreeze, salt or chemical ice removers as these may damage concrete.