

HENRI

STUDIO[®] NC

Fleur de Lys Fountain 5853F

Assembly Instructions

1. Locate a suitable site for your Fleur de Lys Fountain. Site should be level and provide a pleasing viewing angle. You should always follow local electrical codes and use a GFCI Protected outlet.
2. Locate the 7854 Square Riser Base in the center of your site. Level as necessary.
3. Place the 7853 Pedestal on the Square Riser Base.
4. Thread the power cord through the Cord Seal leaving 6-8" of cord to the inside of the 6853 Flower Bowl. Install the Cord Seal in the hole in the center of the Flower Bowl.
5. Place the Bowl on the Pedestal while feeding the cord down through the Pedestal and Square Riser Base and out through the notch in the base.

Cord Seal: the Cord Seal contains a rubber seal, 4 threaded half plates and 4 screws. Unscrew the four screws and separate the four half plates from the rubber seal. Slip the cord through the split and into the hole in the center of the seal. Reinstall the four half plates with the four screws but do not tighten the screws. Insert the seal assembly fully into the hole in the casting, so that it is flush with the inside surface and tighten the screws. The rubber seal will expand to seal the hole and the cord.

6. Install the adapter in the pump output.
7. Connect the 1/2" NKT (No Kink Tubing) to the pump outlet with a clamp. Add a Flow Restrictor to the NKT.
8. Feed the NKT up through the center of the 5853 Fleur de Lys Finial Top and place the Finial in the center of the Bowl.
9. Add water to the fountain and start the pump when there is sufficient water to cover the pump. Adjust the water flow with the Flow Restrictor to obtain pleasing water action. We recommend that the final water level be approximately 1" below the top edge of the Bowl. If the pump does not start on the first attempt, unplug and plug it in again. Sometimes an airlock can occur and this simple restart most frequently clears the lock.

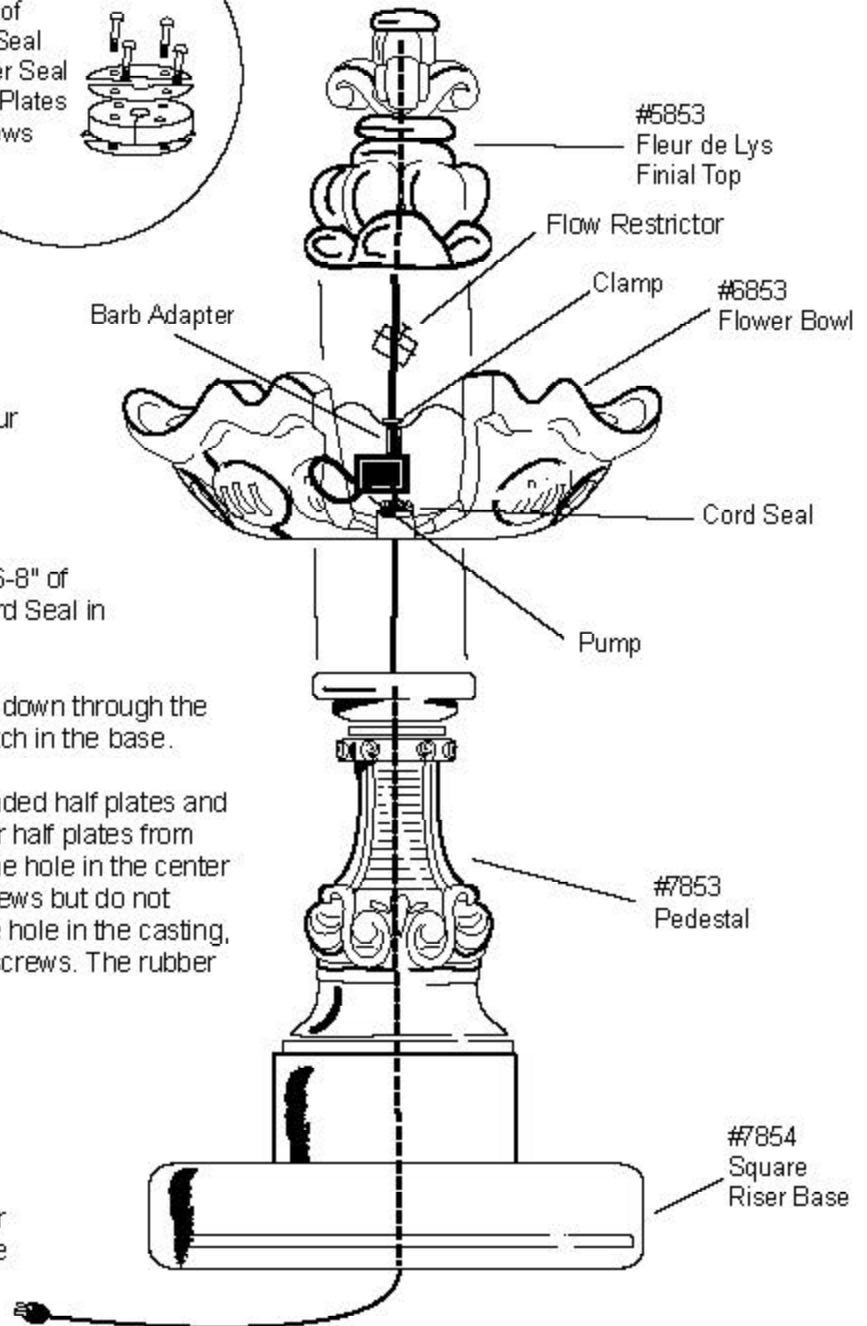
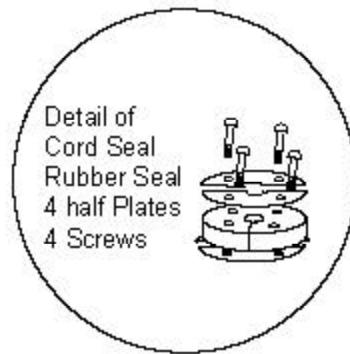

IMPORTANT-WINTER CARE:

Do not allow water to collect and freeze in fountain bowl(s) or shell. Do not allow fountain pieces to sit in a pool of ice. Disassemble entire fountain and pump and store indoors during the winter season.

If you cannot store your fountain indoors during the winter season, you must at least protect it from ice collection or exposure. Protect your fountain during the winter season: first remove the statue(s) and pump, storing them inside if possible. Next, locate the drain plug on the underside of bowl(s) or shell. Remove drain plug to drain any water "trapped" between the walls of the bowl(s) or shell. Then fill the bowl(s) or shell with an absorbent material such as burlap, blankets, etc. Finally, cover the entire fountain with a Henri Fountain Cover. Should condensation droplets form on the inside of the cover, they will be absorbed by the material.

By following these simple and sensible precautions during the winter season, you will protect your fountain for years of beauty and enjoyment!